

**B-SERIES CRAWLER EXCAVATORS
CX700B | CX800B**

CASE
CONSTRUCTION



**BUILT
STRONG**

www.casece.com
EXPERTS FOR THE REAL WORLD
SINCE 1842

B-SERIES

CRAWLER EXCAVATORS

DURABILITY BUILT IN

Case equipment plays a leading role in major infrastructure and construction projects around the world, with Case customers confident that they have the right machine to meet their needs. The CX700B and the CX800B take Case to new levels of productivity and performance. Boasting legendary durability and reliability, these two models are the most powerful machines in the Case line-up.

POWER TO PERFORM

The CX800B and CX700 B are powered by an EU Stage IIIA compliant Isuzu engine, offering 463 and 532 hp of power and an incredible 1980 and 2250 Nm of torque. These electronically controlled power plants offer proven low fuel consumption and reduced exhaust emissions, yet have class-leading performance. Pilot fuel injection contributes to reduced noise levels, while Superpower mode offers speed priority when required.



OPERATOR COMFORT

The widened cab structure offers more leg and foot space, while the extensive glass surface contributes to give an impression of aperture to the operator. Ergonomic layout, intuitive controls and a seat that lays flat ensures optimum comfort and safety to the operator. Additionally, the viscous fluid cab mountings and top quality insulation lead to a stress and fatigue reduction for the operator, boosting productivity and performance. Four positions consoles with return to pre-set modes will suit operators of all sizes and needs.

EASY TO SERVICE

Large wide opening access doors and sturdy non-slip walkways on both sides of the machine provide ease of maintenance for technicians. All filters are centrally grouped with green oil drain facilities for engine oil. A hydraulically-driven cooling fan can be reversed on start up to blow out dust and debris.

BIG ON POWER BIG ON PRECISION CONTROL

Through the Case Intelligent Computer Command Control System (ICCCS) the operator has complete control of engine output and hydraulic power. With a choice of operating modes, the operator has a Superpower function, with automatic Power Boost, for maximum tear out and reduced cycle times.

Customer peace of mind is assured with total protection of the hydraulic system, thanks to a synthetic filter that ensures the lowest possible levels of contamination. This advanced filter provides hydraulic oil change intervals of up to 5,000 hours, reducing downtime and operating costs. Dedicated boom and arm combinations, including a short stick mass excavation format, provide increased productivity in all operating conditions.

The CX800B can handle buckets with capacities up to 5m³.



B-SERIES CRAWLER EXCAVATORS



ENGINE

Both CX700B and CX800B feature a proven SIX cylinder common rail engine meeting Tier 3 emissions standards. The CX800B uses the same well proven fuel efficient Isuzu six cylinder engine as the CX700B. However power is increased by 15% and torque is up by 13.6%. providing increased productivity and performance in all conditions. The engine is EU Stage IIIA compliant. offering low specific fuel consumption and cleaner exhaust emissions. Pilot fuel injection and a hydraulically-driven cooling fan contribute to greatly reduced noise levels. both in the cab and outside the machine.

All Case B series excavators can be equipped with hot climates cooling system (Tropical Package) to face temperatures above 45°.



HYDRAULICS

Case excavators have the power and speed to perform in really tough digging applications. Using an Intelligent Computer Command Control System (ICCCS). the CX700B and the CX800B provide the operator with optimum balance of speed. power and fuel efficiency. whatever the task. Both features a Superpower mode. for speed priority when needed. while the heavy working mode optimises productivity and fuel efficiency. Class-leading digging forces and reduced cycle time contribute to achieve the best performance. Furthermore. the hydraulic system benefits from total protection. thanks to a synthetic filter. which ensures the lowest possible contamination. This advanced filter allows hydraulic oil change intervals of up to 5000 hours. reducing downtime and operating costs for the customer.



CONTROLS

Hydraulic system mode selection (three working modes available) is intuitively set through an advanced engine throttle control. easy reachable from the operator in the fully adjustable right hand console:

- A** A-MODE: for grading. lifting and precision work.
- H** H-MODE: the best balance between productivity and fuel economy.
- SP** SP-MODE: extra speed and power for the most demanding jobs that require maximum productivity.

Operators can store up to 10 auxiliary hydraulic flow settings in the machine's advanced hydraulic control. making it possible to use up to 10 attachments with no manual adjustment to the machine's hydraulic valves.

The display console has a luminosity sensor to ensure that it is easy to read whatever the ambient light conditions.

**BUILT
STRONG**

ULTIMATE ENVIRONMENT

The Case CXB range of hydraulic excavators feature one of the largest, most comfortable cabs in the business. Class-leading levels of visibility, thanks to larger glazed areas and slim pillars, provide the operator with an unparalleled view to the working area.

A comfortable fully reclining operator's seat, standard air conditioning with nine outlet louvres to distribute heat and ventilation ensure that the driver remains comfortable throughout the working day. Cup holders, a clock, a mobile phone holder, a built-in coolbox and numerous storage compartments make the Case cab the ideal environment to ensure maximum productivity.

The cab sits on isolating mountings that reduce noise and vibration, improving the working environment for the operator and boosting productivity.



B-SERIES CRAWLER EXCAVATORS



MAINTENANCE SIMPLICITY

Both models feature large and wide opening doors at each sides of the machine. which are easily accessed by 300 mm wide catwalks. making it easy for technicians to access the engine and hydraulic components. All filters are carefully grouped for ease of access. with engine oil draining by green anti-drop plug. An auto-stop electric fuel pump is fitted as standard. providing rapid 100 liters/min flow to reduce refuelling times and cut work for the operator.



UNDERCARRIAGE

The Case tradition of building strong, durable excavators is continued in the CX700B And in the CX800B. A sturdy carbody, welded internally for added strength, features a reinforced slew frame for maximum strength and durability. This provides the strength to perform in the toughest conditions. Standard two speed travel motors facilitate easy repositioning on the job site. The motors downshift automatically when required and compact high torque final drives ensure traction on the steepest grades and in the deepest mud.

IMPROVED PIN AND BUSHING LIFE

Previously only available on machines above 30 tons. Extended Maintenance Bushings (EMS) are now standard equipment on all Case CX B series excavators. These low maintenance bushings provide longer greasing intervals, greatly reducing daily and weekly maintenance for the operator, and increasing productivity. Anti-friction resin shims in the boom foot and head reduce noise and free play, increasing durability and reliability for the customer.



EMS chrome plated pins with brass bushing



Anti-friction shims



MASS EXCAVATION

Not just incredible earth moving machines, the CX700B and CX800B can be supplied with auxiliary hydraulic hoses to power a range of attachments. Deep groove welding ensures that the booms and arms can withstand the stress of high breakout forces, heavy lifting and attachments such as hydraulic breakers, compactors, demolition shears and crushers.

The CX800B mass excavation is equipped with a 7.25 m main boom and an extra heavy duty 2.98 m dipperstick, for maximum penetration and increased loading productivity. The CX800B can handle buckets with capacities up to 5 m³

B-SERIES

CRAWLER EXCAVATORS

SPECIFICATIONS

CX700B

CX800B

ENGINE		
Make	ISUZU	
Type	AH-6WG1XYSS-01	AH-6WG1XYSS-02
Emission levels	Tier 3	
Common rail, turbo, intercooler, fuel cooler, EGR (Exhaust Gas Recirculator)	Yes	
Direct injection	Electronically controlled	
Number of cylinders	6	
Bore - Stroke (mm)	147 x 154	
Cubic capacity (cc)	15700	
Max power (kW/hp) EEC80/1269	345/463	397/532
(@rpm)	1800	1800
Maximum Torque (Nm)	1980	2250
(@rpm)	1500	
HYDRAULIC SYSTEM		
Max output (l/min)	2 x 440	2 x 500
(@ rpm)	1800	
2 axial piston, variable flow pumps	Yes	
Attachment/Power Boost (bar)	314	
Upperstructure swing (bar)	279	265
Travel (bar)	343	
Oil filtration	6 micron	
Type of oil filter	Synthetic fiber super fine high catch	
SWING		
Max upperstructure swing speed (rpm)	6.5	6.4
Swing torque (kN-m)	241	266
TRAVEL		
	The travel circuit is equipped with axial piston, variable flow motors	
Max travel speed (km/h)	4.1	4.2
Low travel speed (km/h)	3.0	2.9
Speed change is controlled from the instrument panel		
Automatic downshifting	Yes	
Gradeability	70% (35)	
Tractive (daN)	46200	56500
ELECTRICAL SYSTEM		
Circuit (V)	24	
Batteries (V - A/h)	2 x 12 - 92	
Circuit equipped with water-proof connectors	Yes	
Alternator (V - Amp)	24 - 50	
UNDERCARRIAGE		
Upper rollers	3	3
Lower rollers	8	8
Number of track pads	47	51
Type of shoes	Double grouser	
Track pad with standard (mm)	650	
CIRCUIT AND COMPONENT CAPACITIES		
Fuel tank LC (l)	900	
Hydraulic reservoir LC (l)	310	
Hydraulic system (l)	650	720
Travel reduction gear (per side) (l)	15	13.8
Swing reduction gear (l)	13.5	13.5
Engine (including filter change) (l)	52	52
Engine cooling system (l)	108	133

CX700B GENERAL DIMENSIONS

With 7.70 m standard boom

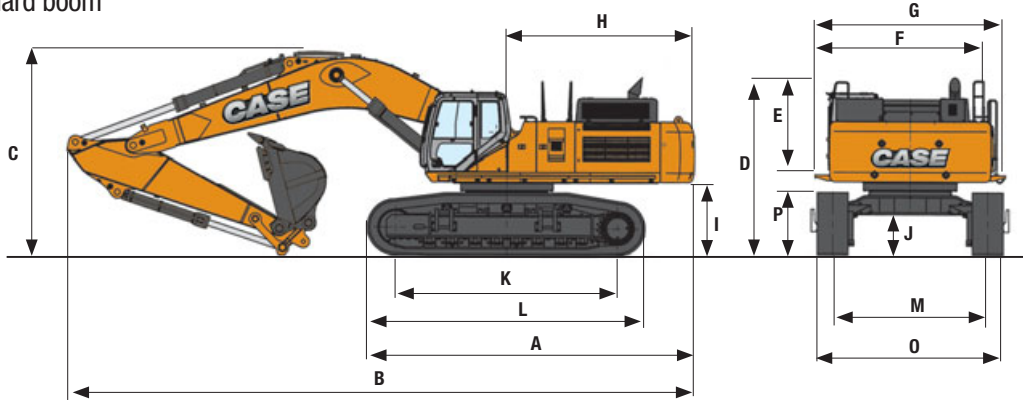

DIPPER LENGTH CX700B

		3.55 m	3.02 m	4.11 m	5.00 m	
A	Overall length (without attachment)	mm	6910	6910	6910	6910
B	Overall length (with attachment)	mm	13290	13250	13300	13170
C	Overall height (with attachment)	mm	4300	4370	4470	5160
D	Overall height (without attachment)	mm	3790	3790	3790	3790
E	Cab height	mm	3480	3480	3480	3480
F	Upper structure overall width (without catwalks)	mm	3390	3390	3390	3390
G	Upper structure overall width (with catwalks)	mm	3990	3990	3990	3990
H	Swing (rear end) radius	mm	4000	4000	4000	4000
I	Clearance height under upper structure	mm	1510	1510	1510	1510
J	Minimum ground clearance	mm	825	825	825	825
K	Wheel base (Center to center of wheels)	mm	4700	4700	4700	4700
L	Crawler overall length	mm	5880	5880	5880	5880
M	Track gauge (Extended)	mm	3250	3250	3250	3250
	Track gauge (Retracted)	mm	2740	2740	2740	2740
O	Undercarriage overall width (Extended) (with 650 mm shoes)	mm	4140	4140	4140	4140
	Undercarriage overall width (Retracted) (with 650 mm shoes)	mm	3630	3630	3630	3630
P	Crawler tracks height	mm	1340	1340	1340	1340

CX700B PERFORMANCE DATA

With 7.70 m standard boom

DIPPER LENGTH			3.55 m	3.02 m	4.11 m	5.00 m
A	Maximum reach at GRP	mm	12900	12600	13400	14300
B	Maximum reach	mm	13160	12870	13650	14600
C	Max. digging depth	mm	8400	7870	8970	9850
D	Max. digging height	mm	11920	12400	12040	12700
E	Max. dumping height	mm	8020	8330	8160	8710
	Arm digging force	kN	224	244	202	175
	With auto power up	kN	245	267	221	192
	Bucket digging force	kN	290	290	290	290
	With auto power up	kN	317	317	317	317

OPERATING WEIGHT

with 3.55 m arm, 2.9 m³ bucket, 650 mm grouser shoes, operator, lubricant, coolant and full fuel tank

CX700B	Weight
	68.900 kg

Counterweight 10.400 kg

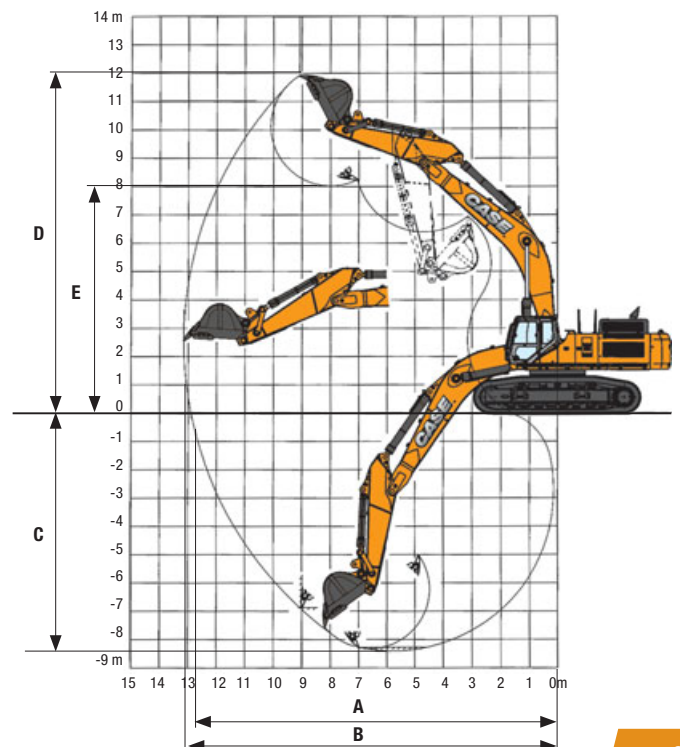

SPECIFICATIONS

CX700B MASS EXCAVATION GENERAL DIMENSION

With 6.58 m Mass Excavation boom - 3.00 m Dipper

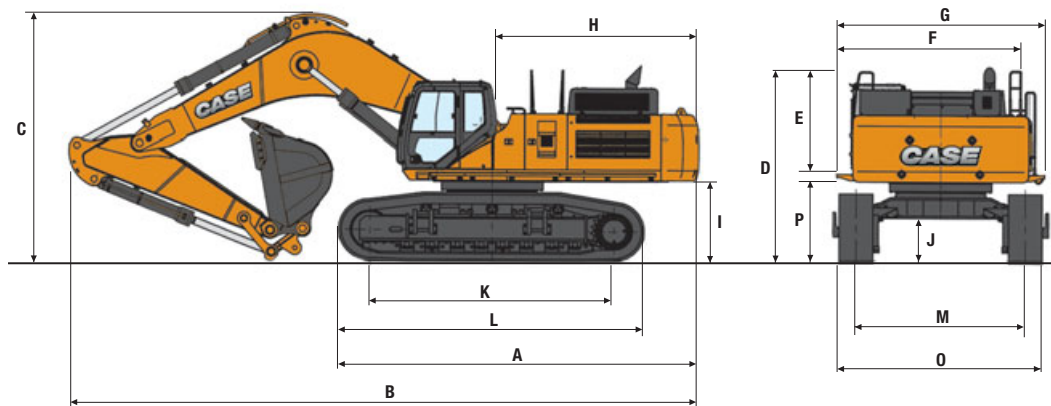

DIPPER LENGTH

3.02 m

A	Overall length (without attachment)	mm	6910
B	Overall length (with attachment)	mm	12280
C	Overall height (with attachment)	mm	5030
D	Overall height (without attachment)	mm	3790
E	Cab height	mm	3480
F	Upper structure overall width (without catwalks)	mm	3390
G	Upper structure overall width (with catwalks)	mm	3990
H	Swing (rear end) radius	mm	4000
I	Clearance height under upper structure	mm	1510
J	Minimum ground clearance	mm	825
K	Wheel base (Center to center of wheels)	mm	4700
L	Crawler overall length	mm	5880
M	Track gauge (Extended)	mm	3250
	Track gauge (Retracted)	mm	2740
O	Undercarriage overall width (Extended) (with 650 mm shoes)	mm	4140
	Undercarriage overall width (Retracted) (with 650 mm shoes)	mm	3630
P	Crawler tracks height	mm	1340
	Height in transport position without bucket. dipper cylinder loosened	mm	4225

CX700B MASS EXCAVATION PERFORMANCE DATA

With 6.58 m Mass Excavation Boom - 3.00 m Dipper

DIPPER LENGTH

3.02 m

A	Maximum reach at GRP	mm	11310
B	Maximum reach	mm	11600
C	Max. digging depth	mm	7080
D	Max. digging height	mm	10880
E	Max. dumping height	mm	6860
	Arm digging force	kN	281
	With auto power up	kN	307
	Bucket digging force	kN	334
	With auto power up	kN	365

* Mass Excavation - attachment

OPERATING WEIGHT

with 3.02 m Arm , 4.0 m³ Bucket , 650 mm grouser shoes, operator, lubricant, coolant and full fuel tank

CX700B MASS EXCAVATION

Weight

69.100 kg

Counterweight 10.400 kg

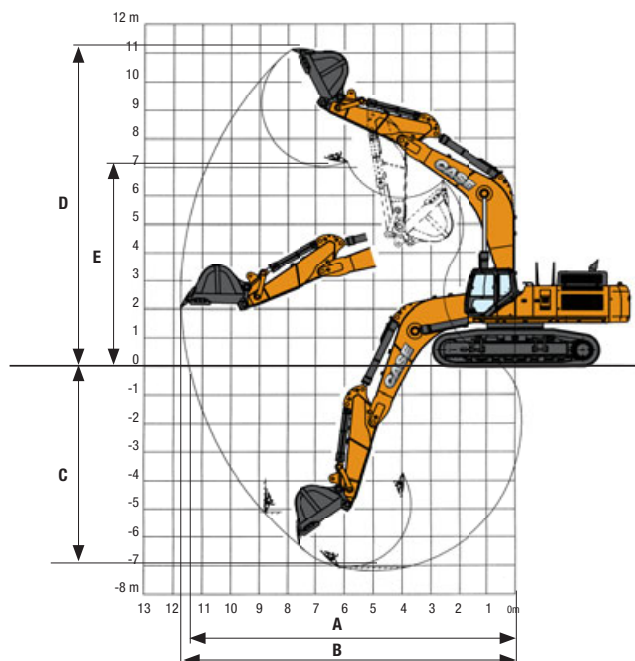

B-SERIES CRAWLER EXCAVATORS

CX800B GENERAL DIMENSIONS

With 8.40 m standard boom

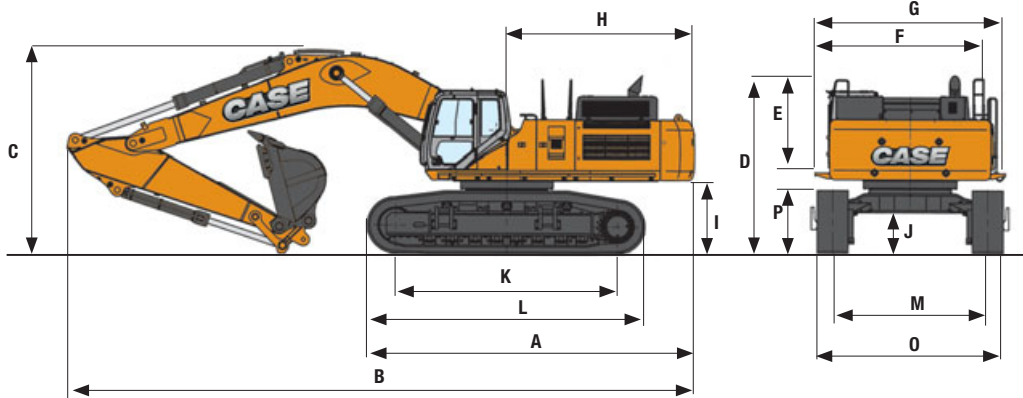

DIPPER LENGTH

		3.66 m	4.44 m	5.62 m	
A	Overall length (without attachment)	mm	7640	7640	7640
B	Overall length (with attachment)	mm	14360	14320	13830
C	Overall height (with attachment)	mm	4810	5000	6300
D	Overall height (without attachment)	mm	3880	3880	3880
E	Cab height	mm	3570	3570	3570
F	Upper structure overall width (without catwalks)	mm	3470	3470	3470
G	Upper structure overall width (with catwalks)	mm	4250	4250	4250
H	Swing (rear end) radius	mm	4300	4300	4300
I	Clearance height under upper structure	mm	1590	1590	1590
J	Minimum ground clearance	mm	890	890	890
K	Wheel base (Center to center of wheels)	mm	5070	5070	5070
L	Crawler overall length	mm	6360	6360	6360
M	Track gauge (Extended)	mm	3450	3450	3450
	Track gauge (Retracted)	mm	2830	2830	2830
O	Undercarriage overall width (Extended) (with 650 mm shoes)	mm	4360	4360	4360
	Undercarriage overall width (Retracted) (with 650 mm shoes)	mm	3740	3740	3740
P	Crawler tracks height	mm	1500	1500	1500

CX800B PERFORMANCE DATA

With 8.40 m standard boom

DIPPER LENGTH

		3.66 m	4.44 m	5.62 m	
A	Maximum reach at GRP	mm	13840	14680	15860
B	Maximum reach	mm	14120	14940	16110
C	Max. digging depth	mm	8690	9470	10560
D	Max. digging height	mm	12910	13600	14300
E	Max. dumping height	mm	8920	9510	10170
	Arm digging force	kN	274	232	195
	With auto power up	kN	330	330	330
	Bucket digging force	kN	330	330	330
	With auto power up	kN	361	361	361

OPERATING WEIGHT

with 3.66 m Arm , 3.3 m³ Bucket , 650 mm grouser shoes, operator, lubricant, coolant and full fuel tank

CX700B MASS EXCAVATION

Weight
80.300 kg

Counterweight 12.500 kg

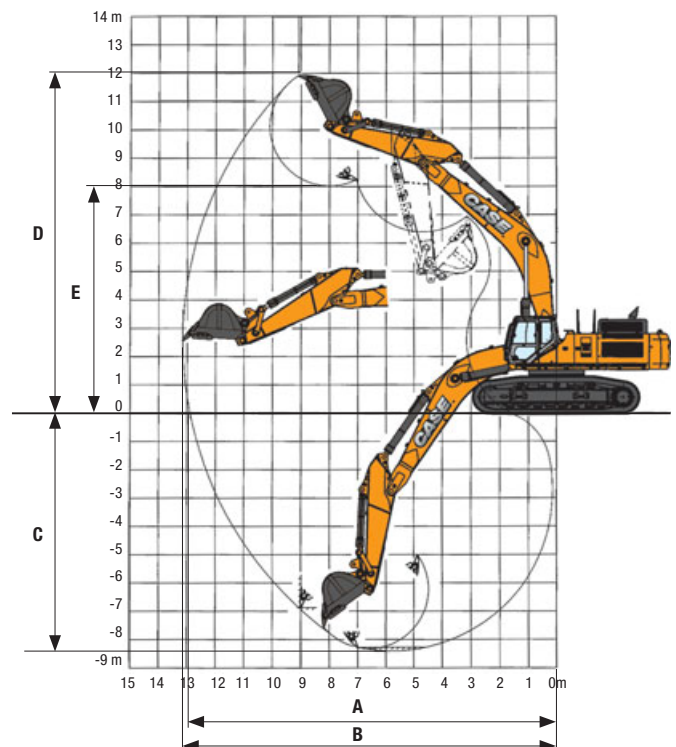

CX800B MASS EXCAVATION GENERAL DIMENSIONS

With 7.25 Mass Excavation Boom

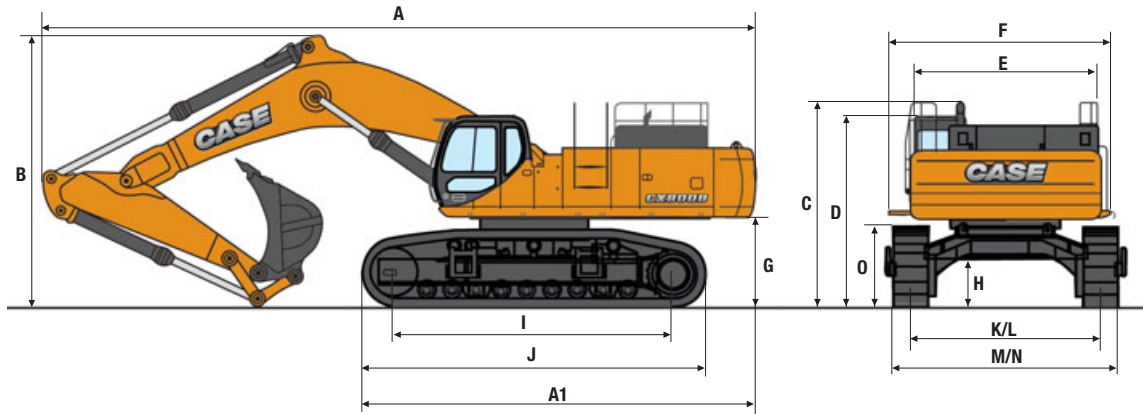

DIPPER LENGTH

Arm 2.98

A	Overall length (with attachment)	mm	13230
A1	Overall length (without attachment)	mm	7640
B	Overall height (with attachment)	mm	5000
C	Overall height (without attachment)	mm	3880
D	Cab height	mm	3570
E	Upper structure overall width (without catwalks)	mm	3470
F	Upper structure overall width (with catwalks)	mm	4250
	Swing (rear end) radius	mm	4300
G	Clearance height under upper structure	mm	1590
H	Minimum ground clearance	mm	890
I	Wheel base (Center to center of wheels)	mm	5070
J	Crawler overall length	mm	6360
K	Track gauge (Extended)	mm	3450
L	Track gauge (Retracted)	mm	2830
M	Undercarriage overall width (Extended) (with 650 mm shoes)	mm	4360
N	Undercarriage overall width (Retracted) (with 650 mm shoes)	mm	3740
O	Crawler tracks height	mm	1500

CX800B MASS EXCAVATION PERFORMANCE DATA

With 7.25 m Mass Excavation Boom

DIPPER LENGTH		Arm 2.98 m	
	Boom length	mm	7250
	Bucket radius	mm	2200
	Bucket wrist action	°	162
A	Maximum reach at GRP	mm	11990
B	Maximum reach	mm	12310
C	Max. digging depth	mm	7030
D	Max. digging height	mm	11760
E	Max. dumping height	mm	7890
	Arm digging force	kN	317
	With auto power up	kN	347
	Bucket digging force	kN	430
	With auto power up	kN	470

* Mass Excavation - attachment

OPERATING WEIGHT

with 2.98 m arm, 4.1 m³ bucket, 650 mm grouser shoes, operator, lubricant, coolant and full fuel tank

CX800B MASS EXCAVATION	Weight
	80.400 kg

Counterweight 12.500 kg

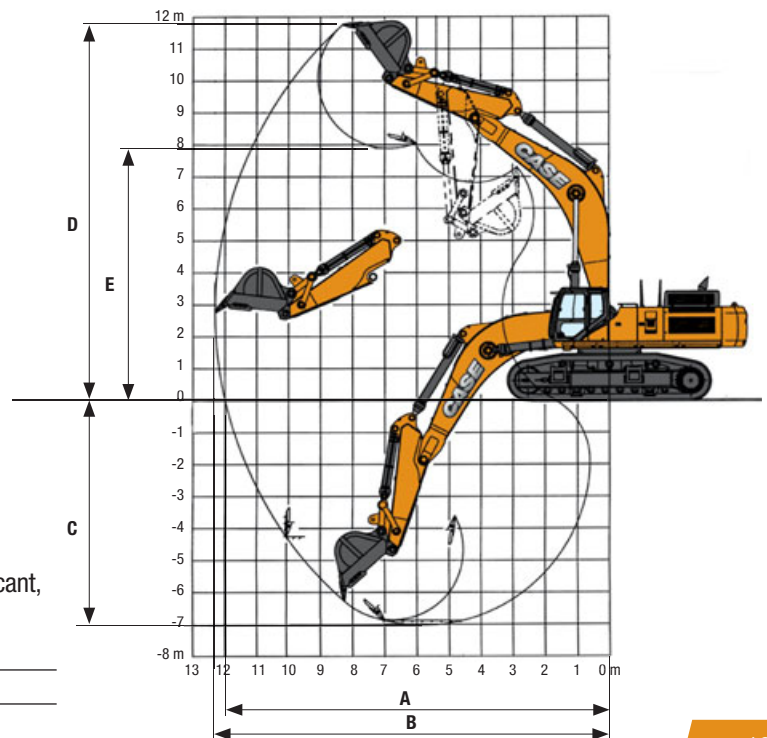

SPECIFICATIONS



www.casece.com
EXPERTS FOR THE REAL WORLD
SINCE 1842

CASE
CONSTRUCTION



Form No. AME5307CCGB - MediaCross Firenze - 02/17

**CASE CONSTRUCTION EQUIPMENT
CONTACT INFORMATION**

CNH INDUSTRIAL - TORINO
Via Plava 80
10135 Torino
Italy

CNH INTERNATIONAL S.A. - LUGANO
Riva Paradiso 14
6902 Paradiso - Lugano
Switzerland

CNH INDUSTRIAL - MIDDLE EAST
DAFZA - Dubai Airport Free Zone
West Wing 4 B, Office 642
P.O. Box 54588, Dubai,
United Arab Emirates

CNH INDUSTRIAL - SOUTH AFRICA
Waterfall Business Park
Bekker Street, Howick Close
1685 Midrand - Johannesburg
Republic of South Africa

NOTE: Standard and optional fittings can vary according to the demands and specific regulations of each country. The illustrations may include optional rather than standard fittings - consult your Case dealer. Furthermore, CNH Industrial reserves the right to modify machine specifications without incurring any obligation relating to such changes.

Conforms to directive 2006/42/EC

