

F-SERIES WHEEL LOADERS
521F | 621F | 721F | 821F | 921F

CASE
CONSTRUCTION



**WORK FASTER,
PRODUCE MORE**

www.casece.com
EXPERTS FOR THE REAL WORLD
SINCE 1842

F-SERIES WHEEL LOADERS



EXPERTS FOR THE REAL WORLD SINCE 1842

- 1842** Case is founded.
- 1869** The first Case portable steam engine - road construction is born!
- 1958** The first Case 4-WD wheel loader, the W9, is introduced.
- 1969** Case begins skid steer loader production.
- 1998** Ride control on loader backhoes and skid steer loaders: another Case first. From 1998 Case Wheel Loaders run FPT engines, leaders in industrial engine technology.
- 2001** The exclusive layout with mid-mounted Cooling Cube and rear mounted engine in Case wheel loaders means clean radiators, reliability and massive bucket payloads.

HERITAGE A TRADITION OF INDUSTRY FIRSTS



2012 Case completes its Tier 4i (EU Stage IIIB) wheel loader range: once again, the first in the industry.*

2015 Case wheel loaders achieve Tier 4 Final / EU Stage IV emissions standards. *

* Only in regulated countries

F-SERIES WHEEL LOADERS



HIGH EFFICIENCY Common Rail Multiple Injection

The engine was developed and manufactured by our award winning sister company FPT Industrial, which produces over 500,000 engines per year and powers world record winners.

The in-house design leverages advanced technologies developed for commercial vehicles and agriculture, and introduces specific tailored solutions for off-road applications.

The NEF N67*, with 6 in-line cylinders and a 6.7 litre displacement, is designed to offer both fuel efficiency and reliability with plenty of power available.

- The air intake flow is increased by a turbocharger with air-to-air cooling.
- The multiple injection delivers best-in-class high torque performance at low rpms.

Our engine technology is so reliable that it is trusted by the French Sea Rescue service for their boats:

what better guarantee could you wish for?

* 521F is fitted with N45 engine

ENGINE KEEP IT SIMPLE



HIGH PAYLOAD Rear mounted engine

Instead of the usual layout, the engine is mounted behind the cooling system. That means an optimized weight distribution as the engine act as a counterweight.

Therefore less dead weight is used which means low stress for axles and brakes.

A better weight distribution is synonymous of up to 15% more payload.



F-SERIES WHEEL LOADERS



- Multiple sintered bronze brake discs are cooled in an oil bath.
- Metal face seals are more resistant to water, fine debris and low temperatures.



HIGH RELIABILITY

Case heavy-duty axles

The heavy-duty axles are tougher, bigger and easier to service thanks to the 3-piece housing design. Wet multiple disc brakes, made of resistant sintered bronze, are located in each wheel hub. Our heavy-duty axles are engineered to support L5 or solid tyres for very abrasive environments. Solid tyres can be factory fitted.

A higher value results from:

- 20-30% lower tyre wear because of no slippage between the wheels;
- reduced fuel consumption because there is no friction in the differential
- reduced downtime for maintenance because of fewer moving components with open differentials.



COST SAVINGS

100% auto lock differential

The heavy duty axles feature open differentials, which means no unnecessary friction is applied to the wheels.

As a result, there is less tyre wear and lower energy losses.

With the 100% Auto-lock, 100% of the available torque is transmitted to the wheels to provide maximum tractive effort.



AXLES AND DIFFERENTIALS

WHEN EFFICIENCY MEETS PRODUCTIVITY



COST SAVINGS FOR STANDARD JOBS

Limited slip axles

- Well known reliable solution
- Lower initial investment
- Good traction is always granted on the 4 wheels



Taking a curve on solid ground		Loading on soft ground	
<p>With limited slip differential:</p> <p>Automatic slip limited engagement</p> <ul style="list-style-type: none"> - Internal losses and wind up - Increased tyre wear 	<p>With 100% diff lock (optional):</p> <p>No engagement (open diff)</p> <ul style="list-style-type: none"> - No energy loss - Less tyre wear 	<p>With limited slip differential:</p> <ul style="list-style-type: none"> - 70% tractive effort transmitted to the wheels - automatic engagement 	<p>With 100% diff lock (optional):</p> <ul style="list-style-type: none"> - 100% tractive effort transmitted to the wheels - automatic or manual engagement

F-SERIES WHEEL LOADERS



HIGH RELIABILITY

Case cooling cube

The unique design of the CASE cooling cube, with five radiators mounted to form a cube instead of overlapping, ensures a constant flow of fresh and clean air from the sides and from the top, to maintain constant fluid temperatures.

The cube structure provides easy access to radiators for a more effective cleaning and serviceability: additional cleaning can also be easily done manually, with separate access to each radiator.

Designed for dusty environment

The cooling system is mounted behind the cab, far from the rear bumper of the machine and from the ground: away from the dust.



CASE COOLING CUBE THE ANTI-CLOGGING SOLUTION



SUPERIOR COOLING EFFECTIVENESS

Heavy-duty cooling

Handling fertilizer, cereals, animal feed or other materials indoors usually leads to radiator clogging.

Case's solution is the Heavy-duty Cooling option, available on 621F and 721F models, which features:

- Extra thin inlet grille that stops bigger particles
- Sealed radiator covers that ensure the cooling air is 100% filtered
- Wide core radiators increase self cleaning with the reversible fan and prevent clogging.



HEAVY-DUTY GRILLE OUTSIDE



Heavy-Duty



Standard

HEAVY-DUTY COOLERS INSIDE



Heavy-Duty

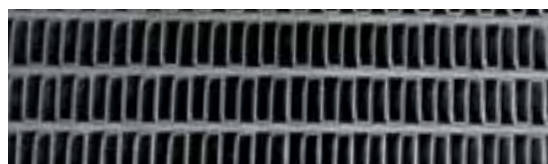

Standard

F-SERIES WHEEL LOADERS



COMFORTABLE AND SAFE CAB

Wider and well protected cab

- Our reinforced cab guarantees protection against roll over (ROPS) and falling objects (FOPS).
- Our cab is also certified P2 level according to European Standards EN143, which means that 94% of airborne particles are filtered. When working in particularly tough conditions, additional pressurisation and particle filtration can be fitted.
- On Waste Handler models windshield guards, provide protection from falling pieces of solid waste.
- The CASE Cab is 2.06 m³ and 1.64 m wide: it is the widest cab in the industry.
- The air suspended seat features a high back design and lumbar adjustment, a saving grace during long working days. It includes seat heaters which warm up cold winter mornings.

CAB AND SEAT COMFORT RULES



HIGH VISIBILITY

Wide glazed surfaces and curved engine hood

You'll feel more confident and work faster with the great all-round visibility provided by the very low shape of the curved rear hood and the ample glazed surfaces.



COMFORTABLE AND SAFE CAB

Low engine vibrations

- The rear mounted engine is far from the cab, further enhancing operator comfort.
- Engine noise and vibrations are reduced by the 3-step injection: pre-, main- and post-injection.

MAIN REASONS TO CHOOSE THE F-SERIES

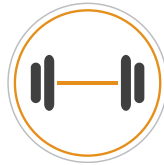

HIGH PAYLOAD

Rear mounted engine assures
15% more payload.
On 721F it means 0,5 t more at
each cycle.



HIGH RELIABILITY

- Heavy-duty axles
- 100% differential lock
- Unique cooling package



COMFORTABLE AND SAFE CAB

- ROPS/FOPS level 2
- Pressurised cab
- Wider glazed area for unbeatable visibility
- Spacious cab



SUPERIOR COOLING EFFICIENCY

- Five radiators form a cube instead of overlapping.
- Designed to maintain constant fluid temperatures.



SAFE AND EASY MAINTENANCE

The rear mounted engine below the electric easy-to open hood is accessible at ground level. Grouped drains rationalise maintenance operations.

F-SERIES WHEEL LOADERS

WASTE HANDLER GUARDS (DIA KIT) FOR 621F AND 721F



Windshield guard



Cylinder guards ejectors

- Lift cylinder guard
- Metal wrapped hoses
- Debris ejector



Rear light guards



Front light guards



Bottom guards (front and rear)



Articulation and front cover



ADDITIONAL OPTIONS AND MAINTENANCE PROTECTION AND EASINESS



The layout of the components under the hood is optimised and results in easier maintenance.



Hood opening and battery on/off switches. In case of flat battery, hood can be opened externally with Remote jump start



Grouped drains for clean and quick oil changes



SAFE AND EASY MAINTENANCE

Ground level serviceability

- One-piece electric hood*

The positioning of the engine at the rear and the easy-to-open electric hood provide fast access to the service points. Jumper cables are available as standard for jump starting the engine if the battery is low.

- Grouped service points

Don't be surprised if you don't see any safety handrails around the hood or steps behind the rear wheels, all service points are easily accessible at ground level. You can do a fast visual check of the hydraulic and transmission oil levels. The three drains are grouped together on the left side, so that fluids are easy and quick to replace.

- Greater safety

All the main service points are easily accessible from the ground, so you can carry out your daily maintenance safely and efficiently.

* On 521F hood opening is mechanical

F-SERIES WHEEL LOADERS



SPECIFICATIONS

ENGINE

	521F	621F	721F	821F	921F
FPT engine _____	N45	N67	N67	N67	N67
Cylinders _____	4	6	6	6	6
Displacement (l) _____	4.5	6.7	6.7	6.7	6.7
Air intake _____	Turbocharger with air-to-air cooling.				
Injection _____	Common Rail Multiple Injection.				
Emission level _____	Tier 2	Tier 3	Tier 3	Tier 3	Tier 2
Max. power (kW) _____	106	128	145	172	190
Max. power (hp) _____	142	172	195	230	255
(@rpm) _____	1800	1800	1800	1800	1800
(SAE J1349)					
Max. torque (N.m) _____	608	730	950	1184	1300
(@rpm) _____	1600	1600	1300	1300	1300
(SAE J1349)					

TRANSMISSION

4-Speed powershift by ZF with Intelligent Clutch Cut Off (ICCO)

	521F	621F	721F	821F	921F
Forward 1 (km/h) _____	6	7	8	7	7
Forward 2 (km/h) _____	11	13	13	12	12
Forward 3 (km/h) _____	22	24	25	23	23
Forward 4 (km/h) _____	36	39	37	37	36
Reverse 1 (km/h) _____	6.4	7	8	7	7
Reverse 2 (km/h) _____	12	14	13	13	13
Reverse 3 (km/h) _____	23	25	26	25	25

AXLES AND DIFFERENTIAL

Rear axle total oscillation _____	24°
A-Choice by ZF _____	Heavy duty axles with open differentials and automatic. 100% lock system on the front differential. 100% tractive effort always, no wheel slip, less tire wear.
B-Choice by ZF _____	Standard axles with limited slip differentials front and rear 73% tractive effort on slippery ground.

TYRES

Tyres _____	17.5R25	20.5R25	20.5R25	23.5R25	23.5R25
-------------	---------	---------	---------	---------	---------

BRAKES

Service brake _____	Maintenance free, self-adjusting wet 4-wheel disc brakes.				
Brake disc area (m ² /hub) _____	0.31	0.39	0.39	0.39	0.47
Parking brake _____	With the negative brake all four wheels are automatically stopped when the engine is stopped.				
Disc brake area (cm ²) _____	58	58	82	82	82

HYDRAULICS

	521F	621F	721F	821F	921F
Valves _____	Rexroth Closed-center, Load sensing hydraulic. Main valve with 3 sections.				
Steering _____	The steering orbitrol hydraulically is actuated with priority valve.				
Automatic functions _____	Bucket Return-to-dig, Boom Return-to-travel, Boom Auto-lift.				
Control type _____	Pilot control with single joystick or two levers.				
Type of pump _____	Tandem Variable displacement pump.				
(l/min) _____	134	171	206	240	282
(@rpm) _____	2000	2000	2000	2000	2000

AUXILIARY HYDRAULIC CIRCUIT

Max flow (l/min) _____	162	162	260	260	260
Max pressure (bar) _____	227	227	224	224	224

SERVICE CAPACITIES

Fuel tank (l) _____	189	248	246	288	288
AdBlue tank (l) _____	41.3	41.3	41.3	41.3	41.3
Cooling system (l) _____	22	26.8	28	30	30
Engine oil (l) _____	12	13	13	13	13
Hydraulic oil tank (l) _____	57	91	91	91	91
Total hydraulic system oil (l) _____	114	148	180	180	200
Front and Rear Axles (l) _____	22+22	22+22	35+35	40+40	42+40
Transmission oil (l) _____	19	27	34	34	34

CAB PROTECTION

Protection against falling objects (FOPS) _____	ISO EN3449
Protection against roll over (ROPS) _____	ISO EN13510

SOUND AND VIBRATION

In the cab - LpA (dB) _____ (ISO 6595/6396/3744)	70	70	72	72	72
Outside - LwA (dB) _____ (SAE J88 SEP80)	102	104	105	107	107
Vibrations _____	Operator 's seat meets the criteria of ISO 7096:2000. The vibrations transmitted do not exceed 0.5 m/s ²				

ELECTRICAL SYSTEM

24V. Batteries 2 x 12V. Alternator (A) _____	65
--	----

F-SERIES WHEEL LOADERS

521F GENERAL DIMENSIONS

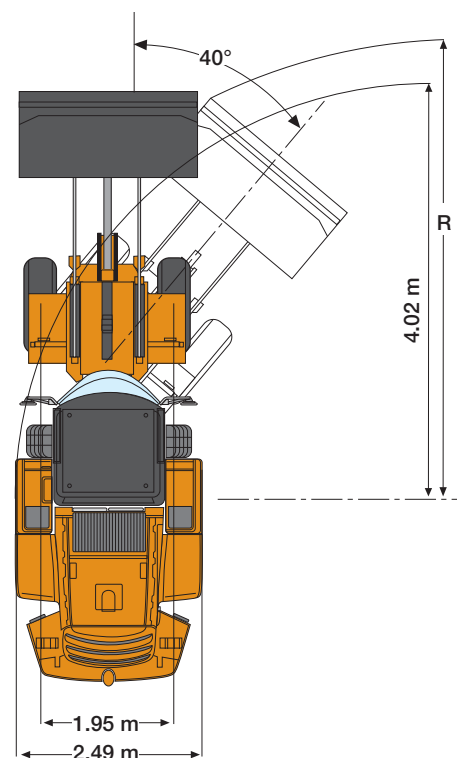
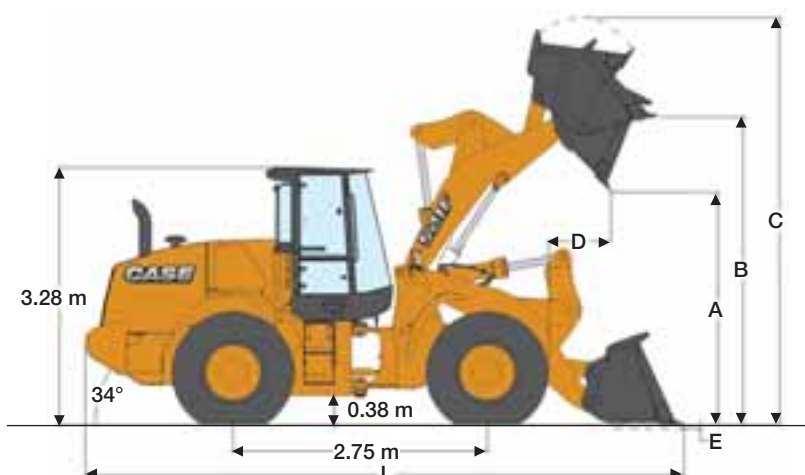

LOADER SPEED:

Raising time (loaded)	5.4 sec
Dump time (loaded)	1.2 sec
Lowering time (empty, power down)	3.9 sec
Lowering time (empty, float down)	3.9 sec

521F	Z-bar bucket				XR bucket				XT bucket		
	2.1 m ³		1.7 m ³ w/QC		1.9 m ³		1.7 m ³ w/QC		1.7 m ³ w/QC		
	edge	teeth + segment	edge	teeth	edge	teeth	edge	teeth	edge	teeth	
Volume, heaped (SAE)	m ³	2.1	2.1	1.7	1.7	1.9	1.8	1.7	1.7	1.7	1.7
Volume at 110% fill factor	m ³	2.3	2.3	1.9	1.9	2.1	2.0	1.9	1.9	1.9	1.9
Bucket Payload	kg	3478	3475	3535	3584	2977	2975	2947	2994	3249	3296
Maximum material density	ton/m ³	1.7	1.7	2.1	2.1	1.6	1.6	1.7	1.8	1.9	1.9
Bucket outside width	m	2.49	2.54	2.44	2.44	2.49	2.54	2.44	2.44	2.44	2.44
Bucket weight	kg	857	877	1137	1065	821	842	1137	1065	1117	1045
Tipping load - straight	kg	8150	8145	8317	8415	7011	7010	6985	7080	7634	7728
Tipping load - Articulated at 40°	kg	6957	6949	7069	7167	5955	5950	5894	5989	6497	6591
Breakout force	kg	7591	7781	7104	6959	8094	8366	7077	6933	8288	8124
Lift capacity from ground	kg	8889	8979	10620	10700	8830	8827	8689	8773	10236	10365
A - Dump height at 45° at full height	m	2.62	2.55	2.58	2.56	3.04	2.97	2.96	2.94	2.5	2.49
B - Hinge pin height	m	3.61	3.61	3.61	3.61	3.99	3.99	3.99	3.99	3.75	3.75
C - Overall height	m	4.75	4.75	4.77	4.77	5.06	5.06	5.14	5.14	4.94	4.94
D - Bucket reach at full height	m	1.12	1.19	1.18	1.22	1.05	1.12	1.16	1.19	1.23	1.27
E - Dig depth	cm	8	8	7	5	11	11	10	9	19	18
L - Overall length with bucket on the ground	m	6.83	6.94	6.90	6.92	7.11	7.21	7.24	7.27	7.05	7.07
R - Turning radius to front corner of the bucket	m	5.5	5.6	5.5	5.5	5.7	5.7	5.6	5.7	5.5	5.6
Bucket rollback in carry position	°	43	43	48	48	44	44	50	50	52	52
Dump angle at full height	°	55	55	50	50	51	51	46	46	62	62
Machine operating weight with XHA2 (L3) tyres	kg	10448	10468	10728	10656	10582	10602	10897	10825	11189	11117
Machine operating weight with VSDL (L5) tyres	kg	11088	11108	11368	11296	11222	11242	11537	11465	11829	11757

621F GENERAL DIMENSIONS

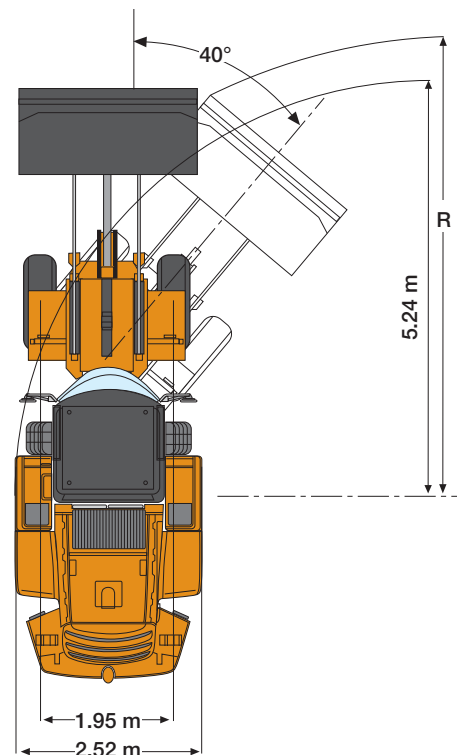
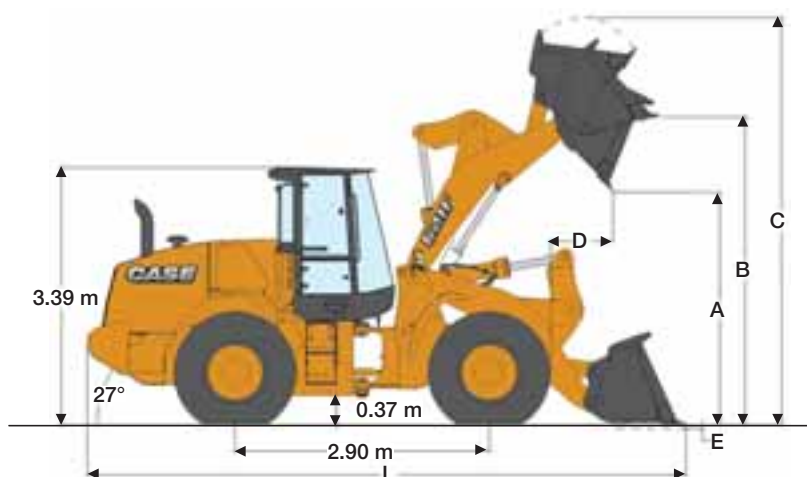

LOADER SPEED:

Raising time (loaded)	6.3 sec
Dump time (loaded)	1.2 sec
Lowering time (empty, power down)	4.4 sec
Lowering time (empty, float down)	4.4 sec

621F		Z-bar bucket				XR bucket				XT bucket	
		2.4 m ³		2.0 m ³ w/QC		2.2 m ³		2.0 m ³ w/QC		2.0 m ³ w/QC	
		edge	teeth	edge	teeth	edge	teeth	edge	teeth	edge	teeth
Volume, heaped (SAE)	m ³	2.4	2.4	2.0	2.0	2.2	2.1	2.0	2.0	2.0	2.0
Volume at 110% fill factor	m ³	2.6	2.6	2.2	2.2	2.4	2.3	2.2	2.2	2.2	2.2
Bucket Payload	kg	4371	4367	4519	4570	3707	3704	3708	3757	4092	4157
Maximum material density	ton/m ³	1.84	1.85	2.26	2.29	1.70	1.73	1.85	1.88	2.05	2.08
Bucket outside width	m	2.49	2.54	2.49	2.49	2.49	2.54	2.49	2.49	2.49	2.49
Bucket weight	kg	941	968	1242	1168	890	916	1242	1168	1242	1168
Tipping load - straight	kg	9964	9962	10325	10426	8488	8485	8527	8624	9360	9489
Tipping load - Articulated at 40°	kg	8741	8735	9038	9139	7414	7407	7416	7514	8185	8314
Breakout force	kg	9819	10097	9472	9272	11233	11591	9503	9310	10595	10395
Lift capacity from ground	kg	9857	9956	13068	13175	11411	11410	11348	11436	14642	14851
A - Dump height at 45° at full height	m	2.75	2.68	2.71	2.69	3.24	3.17	3.19	3.18	2.65	2.63
B - Hinge pin height	m	3.83	3.83	3.83	3.83	4.24	4.24	4.24	4.24	3.96	3.96
C - Overall height	m	5.04	5.04	5.05	5.05	5.45	5.45	5.46	5.46	5.23	5.23
D - Bucket reach at full height	m	1.08	1.16	1.12	1.16	1.01	1.01	1.22	1.25	1.23	1.26
E - Dig depth	cm	9	9	9	8	9	9	10	9	18	17
L - Overall length with bucket on the ground	m	7.47	7.57	7.53	7.56	7.75	7.86	7.93	7.97	7.78	7.81
Overall length without bucket	m	6.28	6.28	6.28	6.28	6.69	6.69	6.69	6.69	6.20	6.20
R - Turning radius to front corner of the bucket	m	5.7	5.8	5.7	5.7	5.9	6.0	5.9	5.9	5.8	5.8
Bucket rollback in carry position	°	44	44	49	49	46	46	51	51	58	58
Dump angle at full height	°	51	51	46	46	46	46	41	41	55	55
Machine operating weight with XHA2 (L3) tyres	kg	12191	12218	12492	12418	12336	12362	12688	12614	12569	12459
Machine operating weight with X-mine D2 (L5) tyres	kg	12890	12917	13191	13117	13035	13061	13387	13313	13268	13158

F-SERIES WHEEL LOADERS

721F GENERAL DIMENSIONS

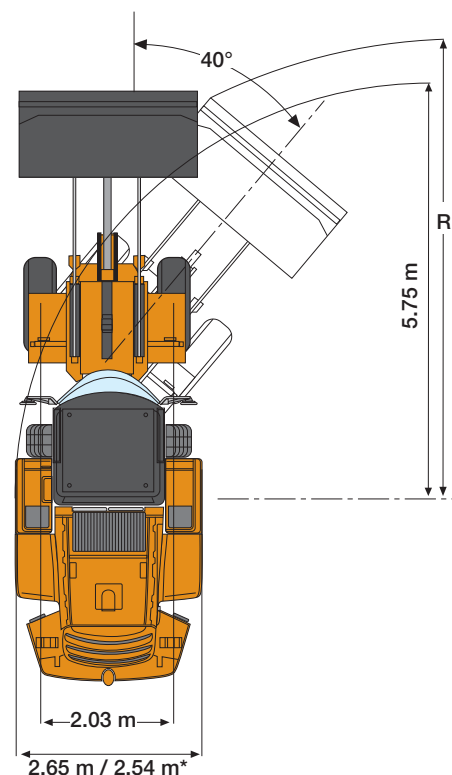
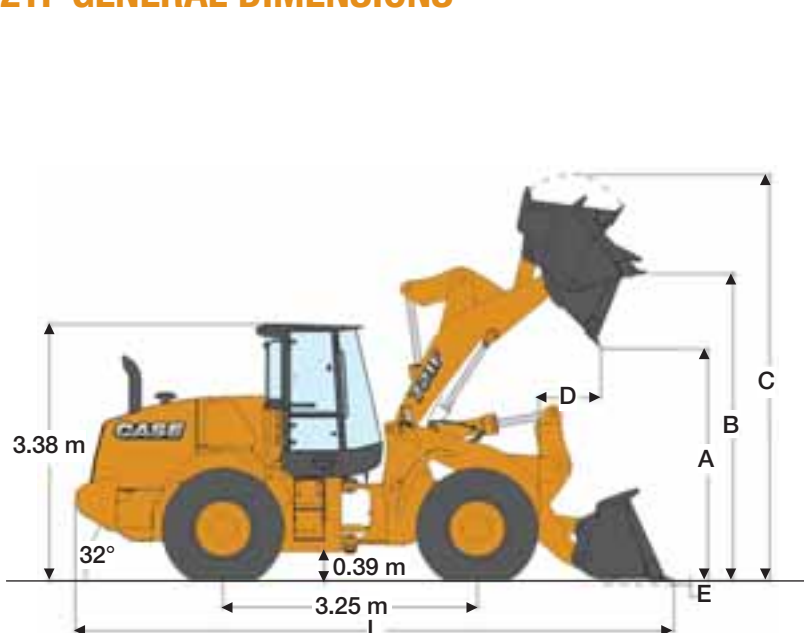

LOADER SPEED

Raising time (loaded)	5.2 sec
Dump time (loaded)	1.2 sec
Lowering time (empty, power down)	2.5 sec
Lowering time (empty, float down)	2.4 sec

* with narrow tyres

721F		Z-bar bucket				XR bucket				XT bucket	
		2.7 m ³		2.4 m ³ w/QC		2.7 m ³		2.4 m ³ w/QC		2.4 m ³ w/QC	
		edge	teeth	edge	teeth	edge	teeth	edge	teeth	edge	teeth
Volume, heaped (SAE)	m ³	2.7	2.7	2.4	2.4	2.7	2.7	2.4	2.4	2.4	2.4
Volume at 110% fill factor	m ³	3.0	3.0	2.6	2.6	2.4	2.3	2.2	2.2	2.2	2.2
Bucket Payload	kg	5440	5369	5299	5325	4533	4464	4385	4409	4924	4946
Maximum material density	tonnes/m ³	2.0	2.0	2.2	2.2	1.7	1.7	1.8	1.8	2.1	2.1
Bucket outside width	m	2.73	2.73	2.47	2.47	2.73	2.73	2.47	2.47	2.47	2.47
Bucket weight	kg	1237	1344	1656	1619	1237	1344	1656	1619	1627	1590
Tipping load - straight	kg	12435	12292	11356	11405	10419	10280	10129	10177	11280	11326
Tipping load - Articulated at 40°	kg	10881	10738	10599	10649	9066	8927	8770	8818	9847	9893
Breakout force	kg	14236	12885	12185	11284	14160	12817	12040	11151	12016	11193
Lift capacity from ground	kg	13607	13480	13419	13462	11302	11177	11072	11115	13096	13111
A - Dump height at 45° at full height	m	2.93	2.86	2.82	2.74	3.33	3.26	3.21	3.14	2.77	2.69
B - Hinge pin height	m	3.98	3.98	3.98	3.98	4.37	4.37	4.37	4.37	4.16	4.16
C - Overall height	m	5.52	5.52	5.51	5.51	5.91	5.91	5.90	5.90	5.67	5.66
D - Bucket reach at full height	m	1.13	1.21	1.28	1.36	1.13	1.21	1.28	1.36	1.27	1.36
E - Dig depth	cm	7.4	7.4	6.2	6.7	7.6	7.7	6.5	6.9	21	21.3
Overall length without bucket	m	6.53	6.53	6.53	6.53	6.85	6.85	6.85	6.85	6.52	6.52
L - Overall length with bucket on the ground	m	7.65	7.76	7.83	7.95	7.65	7.76	8.18	8.30	8.12	8.24
R - Turning radius to front corner of the bucket	m	6.3	6.4	6.3	6.3	6.5	6.5	6.5	6.5	6.2	6.3
Bucket rollback in carry position	°	43	43	38	38	41	41	36	36	58	58
Dump angle at full height	°	55	55	61	61	55	55	61	61	54	54
Machine operating weight with XHA2 (L3) tyres	kg	14225	14532	14844	14807	14644	14751	15063	15026	14915	14878
Machine operating weight with X-mine D2 (L5) tyres	kg	14924	15231	15543	15506	15343	15450	15762	15725	15614	15577

821F GENERAL DIMENSIONS

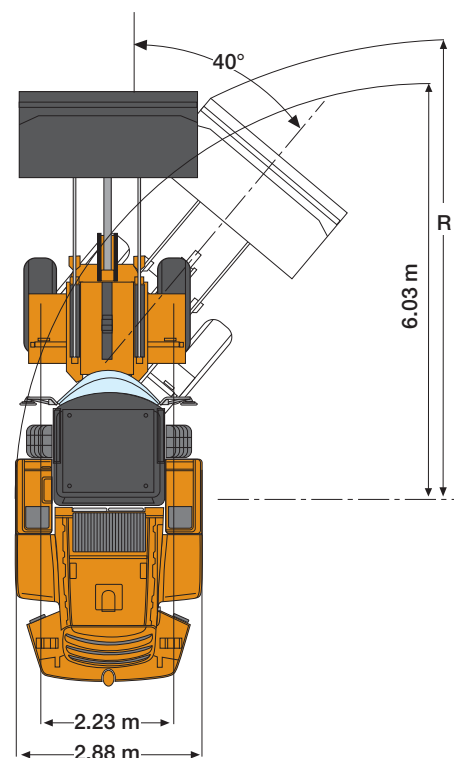
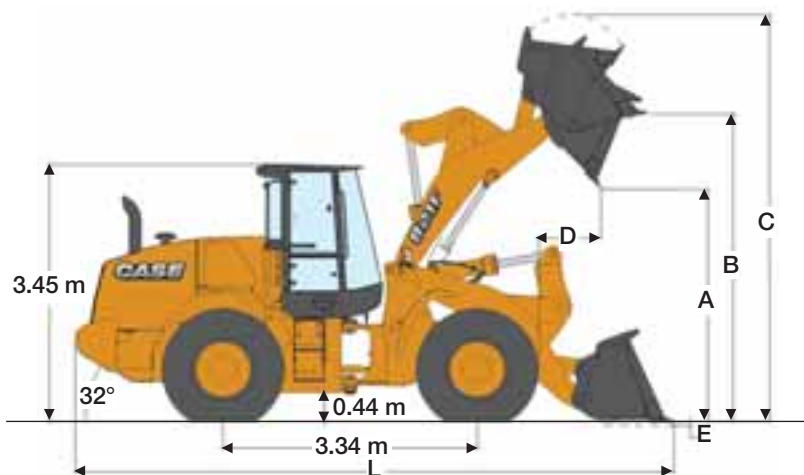

LOADER SPEED

Raising time (loaded)	6.2 sec
Dump time (loaded)	1.2 sec
Lowering time (empty, power down)	2.9 sec
Lowering time (empty, float down)	2.5 sec

821F		Z-bar bucket				XR bucket			
		3.4 m ³		3.2 m ³		3.2 m ³		2.8 m ³	
		edge	teeth	edge	teeth	edge	teeth	edge	teeth
Volume, heaped (SAE)	m ³	3.4	3.2	3.2	3.1	3.2	3.1	2.8	2.5
Volume at 110% fill factor	m ³	3.7	3.5	3.5	3.4	3.5	3.4	3.1	2.7
Bucket Payload	kg	6146	6268	6184	6295	4878	4970	4968	5123
Maximum material density	tonnes/m ³	1.80	1.94	1.93	2.03	1.53	1.60	1.77	2.05
Bucket outside width	m	2.95	2.95	2.94	2.94	2.95	2.94	2.95	2.94
Bucket weight	kg	1550	1460	1520	1430	1520	1430	1366	1276
Tipping load - straight	kg	14203	14465	14284	14523	11366	11562	11547	11889
Tipping load - Articulated at 40°	kg	12293	12536	12367	12590	9756	9941	9936	10246
Breakout force	kg	15076	16133	15473	16676	15721	16953	18032	19496
Lift capacity from ground	kg	17976	18137	18055	18201	13725	13885	13938	14237
A - Dump height at 45° at full height	m	2.94	2.86	2.96	2.88	3.34	3.33	3.50	3.43
B - Hinge pin height	m	4.12	4.12	4.12	4.12	4.56	4.56	4.56	4.56
C - Overall height	m	5.49	5.49	5.45	5.45	5.89	5.89	5.73	5.73
D - Bucket reach at full height	m	1.17	1.13	1.15	1.27	1.26	1.38	1.14	1.26
E - Dig depth	cm	7	5	7	5	14	11	14	11
L - Overall length with bucket on the ground	m	7.94	8.06	7.90	8.03	8.39	8.52	8.23	8.35
Overall length without bucket	m	6.78	6.78	6.78	6.78	7.24	7.24	7.24	7.24
R - Turning radius to front corner of the bucket	m	6.6	6.7	6.6	6.6	6.9	6.9	6.8	6.8
Bucket rollback in carry position	°	44	44	44	44	43	43	43	43
Dump angle at full height	°	55	55	55	55	49	49	49	49
Machine operating weight with XHA2 (L3) tyres	kg	17694	17604	17664	17574	18046	17956	17892	17802
Machine operating weight with VSDL (L5) tyres	kg	18592	18502	18562	18472	18944	18854	18790	18700

F-SERIES WHEEL LOADERS

921F GENERAL DIMENSIONS

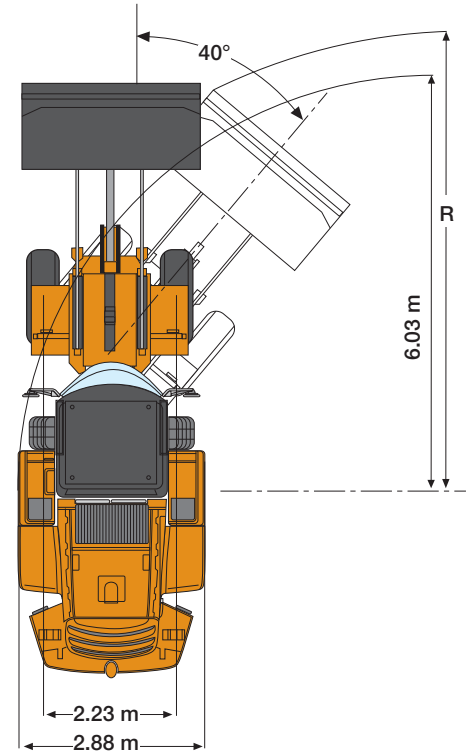
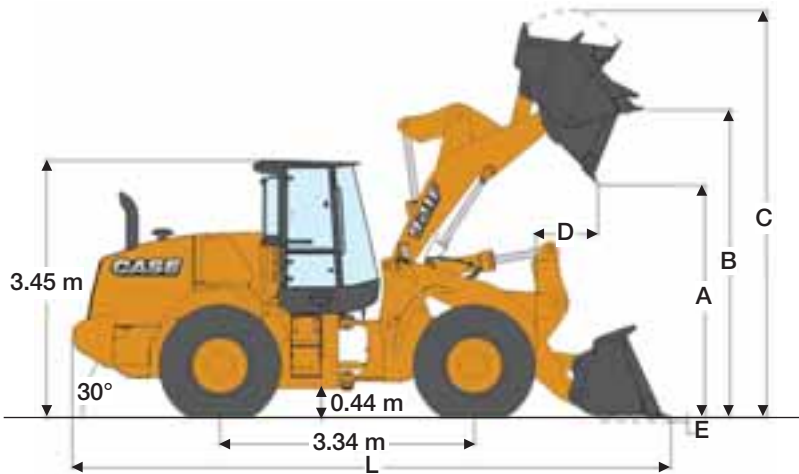

LOADER SPEED

Raising time (loaded)	6.2 sec
Dump time (loaded)	1.4 sec
Lowering time (empty, power down)	3.8 sec
Lowering time (empty, float down)	3.1 sec

921F		Z-BAR bucket 4.0 m ³		XR bucket 4.0 m ³		
		edge	teeth	edge	teeth	
	Volume, heaped (SAE)	m ³	4.0	3.8	4.0	3.8
	Volume at 110% fill factor	m ³	4.4	4.2	4.4	4.2
	Bucket Payload	kg	7205	7245	5695	5735
	Maximum material density	tonnes/m ³	1.8	1.9	1.4	1.5
	Bucket outside width	m	2.98	2.98	2.98	2.98
	Bucket weight	kg	1922	1807	1922	1807
	Tipping load - straight	kg	16765	16867	13361	13463
	Tipping load - Articulated at 40°	kg	14409	14491	11389	11471
	Breakout force	kg	17738	18886	18061	19209
	Lift capacity from ground	kg	21587	21735	16739	16887
	A - Dump height at 45° at full height	m	2.86	2.86	3.22	3.22
	B - Hinge pin height	m	4.12	4.12	4.56	4.56
	C - Overall height	m	5.71	5.71	6.15	6.15
	D - Bucket reach at full height	m	1.05	1.16	1.19	1.3
	E - Dig depth	cm	7	7	14	14
	L - Overall length with bucket on the ground	m	7.92	8.07	8.41	8.56
	Overall length without bucket	m	6.78	6.78	7.24	7.24
	R - Turning radius to front corner of the bucket	m	6.6	6.7	6.6	6.7
	Bucket rollback in carry position	°	44	44	43	43
	Dump angle at full height	°	50	50	44	44
	Machine operating weight with XHA2 (L3) tyres	kg	20068	19953	20210	20095
	Machine operating weight with VSDL (L5) tyres	kg	20966	20851	21108	20993

TELEMATICS*

ANTICIPATION AND CONTROL



THE SCIENCE BIT

The Case SiteWatch telematics system uses a high-tech control unit mounted on each machine to collate information from that machine and from GPS satellites. This data is then sent wirelessly through the mobile communication networks to the Case Telematics Web Portal.

SiteWatch: centralised fleet control benefits at your fingertips

📶 Measure your true asset availability and optimise it

- Eliminate the “phantom fleet”: SiteWatch allows to identify spare units or under loaded machines on each site.
- Become able to reallocate units where they are more needed.
- Forward Maintenance Planning is easier since the actualised working hours are always available.
- Extend the benefits of SiteWatch to the rest of your fleet: SiteWatch can be installed on the units of other brands as well.

📶 Challenge your Total Cost of Ownership!

- Being able to compare the fuel usage of different machine types will allow you choose the right equipment.
- Save on transport costs with planned and grouped maintenance tasks.
- Peace of mind, optimised uptime and lower repair costs: with preventive maintenance you can for example be alerted if the engine needs to be serviced and avoid a disruptive breakdown.
- Be able to compare your asset Return On Investment on different sites.
- Your equipment is used only during working hours. You can set up alerts so that you know if it is in use during the weekend or at night.
- Integrate with the programmed maintenance package, so that you can be sure every machine is at the right place at the right time.

📶 More Safety, Lower Insurance Premium

- Keep thieves away: dissuade them from attacking your asset because it is geo-localised. SiteWatch is hidden so that thieves can't find it quickly.
- Your fleet is used only where you decide. You can define a virtual fence and receive an email when a machine exits that perimeter.



www.casece.com
EXPERTS FOR THE REAL WORLD
SINCE 1842

CASE
CONSTRUCTION



Form No. AME5401CCGB - Printed in Italy - MediaCross Firenze - 11/15

**CASE CONSTRUCTION EQUIPMENT
CONTACT INFORMATION**

CNH INDUSTRIAL - TORINO
Via Plava 80
10135 Torino
Italy

CNH INTERNATIONAL S.A. - LUGANO
Riva Paradiso 14
6902 Paradiso - Lugano
Switzerland

CNH INDUSTRIAL - MIDDLE EAST
DAFZA - Dubai Airport Free Zone
West Wing 4 B, Office 642
P.O. Box 54588, Dubai,
United Arab Emirates

CNH INDUSTRIAL - SOUTH AFRICA
Waterfall Business Park
Bekker Street, Howick Close
1685 Midrand - Johannesburg
Republic of South Africa

NOTE: Standard and optional fittings can vary according to the demands and specific regulations of each country. The illustrations may include optional rather than standard fittings - consult your Case dealer. Furthermore, CNH Industrial reserves the right to modify machine specifications without incurring any obligation relating to such changes.

Conforms to directive 2006/42/EC

